

CUSHION BELT



Reorder #	Size	Unit
301200	Universal	Ea
301201	Universal	Ea

Caution: Federal law restricts this device to sale by or on the order of a physician or licensed health care professional.

Indications - The Skil-Care Cushion Belt is recommended for use with a patient who:

- Requires a safety belt while seated in the wheelchair
- Requires a reminder not to leave the wheelchair without assistance
- Requires a reminder not to leave the bed without assistance

Contraindications for Use - Do not use this device for a patient who:

- Slides down in the wheelchair
- Requires posture support
- Moves toward the foot of the bed
- Has a history of easily removing belt-style, vest-style, and poncho-style restraints
- Is in a geri-chair or lounge chair. This device is intended for wheelchair and bed use only

Wheelchair Application

1. Before seating patient in wheelchair, make certain that both brakes are locked and both footrests are positioned to the sides of the chair. Seat patient as far back in the wheelchair as possible. Position footrests to the front of the chair and place patient's feet on them.
2. Place the Cushion Belt at the patient's waist, strap loops facing away from the patient.
3. Criss-cross the straps behind the patient. Thread the strap from patient's right side through the loop on his/her left side. Thread the strap from the patient's left side through the loop on his/her right side.
4. Pull both straps through both loops until Cushion Belt fits snugly. Note: Straps should not be so snug as to interfere with patient's breathing. You should be able to slide your open hand between the device and the patient.
5. Wrap the strap at the patient's right side once around the metal bar just behind the right armrest pad. Repeat on left side. See illustration A.
6. Behind the wheelchair, pass both waist straps through the space between the wheelchair backrest and seat.
7. Cross the straps, wrapping one around the other as shown in illustration B.
8. Position left strap at right kick-spur and right strap at the left kick-spur as shown in illustration C.
9. Wrap the strap several times around the kick-spur as shown in illustration D. Leave some excess so that you can proceed to next step.
10. Wrap the strap around the vertical over the kick spur. Note that the strap is also wrapped around itself. See illustration E.
11. Tuck the loose end under the last wrap and pull down to secure. See illustration F. This creates a knot-free closure.

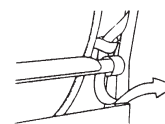

Illustration A



Illustration B

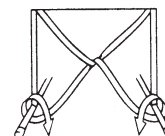

Illustration C

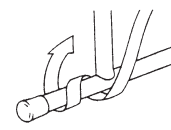

Illustration D

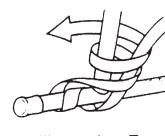

Illustration E

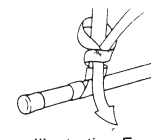
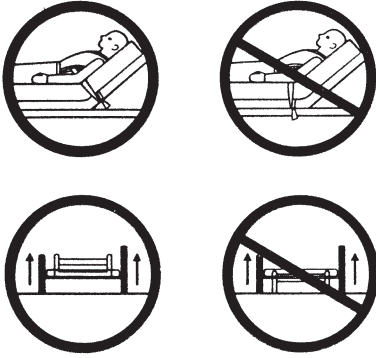

Illustration F

See **important warning and cautions** on reverse side.

Bed Application

1. Seat patient on side of bed. Place Cushion Belt at patient's waist, strap loops facing away from the patient.
2. Criss-cross the straps behind the patient. Thread the strap from the patient's right side through the loop on his/her left side. Thread the strap from the patient's right side through the loop on his/her right side.
3. Pull both straps through both loops until Cushion Belt fits snugly.
Note: Straps should not be so tight as to interfere with patient's breathing. You should be able to slide your open hand between the device and the patient.



4. Position patient's hips to the point where the bed forms a "V" when raised.

Always secure straps to the part of the bed that moves when patient is raised or lowered. Never attach straps to bed rails or any part of the bed that does not move when raised and lowered.

5. Raise and lock bed rails before leaving patient.

Always raise and lock bed rails when patient is wearing Cushion Belt. Never leave bed rails in lowered position when patient is unattended.

Laundering

This device should not be laundered or dried at temperatures that exceed 180°F (82° C). Do not use bleach.

See important warning and cautions below.

Always...

Always inspect condition of device.



Always read package insert to determine if device is intended for wheelchair and/or bed use.



Always monitor patients in restrictive devices. Make certain to follow your facility's procedures for periodic release, toileting, and exercise.



Never...

Never use a device that has worn or frayed fabric or webbing. Discard damaged units immediately. Do not alter products.



Never use a Skil-Care device as a restraint in a motor vehicle.



Never place a patient wearing a restrictive device in a place where he/she is not easily monitored.



(Date of issue: 9/3/96)

Skil-Care[™]
CORPORATION

Advanced design for nursing and therapy.[™]

29 Wells Ave., Yonkers, NY 10701

914-963-2040

800-431-2972

Fax: 914-963-2567

Visit us online
at Skil-Care.com