



CREST ELITE PILLOW SPEAKERS

Durable, Economical & Repairable

Great quality and affordable pricing
combine for a better customer experience.

CREST

EliteDigital™

CREST

EliteInfrared™

UPGRADE YOUR PILLOW SPEAKERS

CREST

EliteDigital™



- AutoSense™ proprietary technology automatically detects and connects to any hospital grade TV
- Excellent audio
- Crisp gentle press buttons
- Designed for infection control
- Low flat fee Crest repairs or DIY

LATEX-FREE

OXYGEN SAFE

2
YEAR
WARRANTY

RECOGNIZED
COMPONENT
ETL
US
Intertek

CREST
HEALTHCARE®

800.328.8908

800.369.9207

CrestHealthcare.com

CREST PATENTED INFRARED PILLOW SPEAKERS

CREST

Elite Infrared™



- Elite Infrared is configurable to control a TV plus either a Set Top Box or DVD/Blu-ray player
- Universal TV remote with traditional pillow speaker functionality such as nurse call & environmental controls
- Excellent audio
- Crisp gentle press buttons
- Designed for infection control
- Low flat fee Crest repairs or DIY



PATENTED

LATEX-FREE

OXYGEN SAFE

2
YEAR
WARRANTY



CREST
HEALTHCARE®

800.328.8908

800.369.9207

CrestHealthcare.com

Backlit Pillow Speakers

FOR RAULAND[®] RESPONDER[®] 5, HILLROM[®]
NAVICARE[®], JERON[®] PROVIDER[®] 790,
WEST-COM[®] & AMPLION[®]

CREST

HEALTHCARE[®]

Backlit Elite Digital™ & Elite Infrared™ Pillow Speakers

- Improve Patient Experience with illuminated buttons for visibility in low-light environments
- Eliminate Multiple Remotes with patented infrared technology
- Reduce Facility Costs with low flat fee Crest repairs or DIY
- Buy With Confidence
FDA registered and UL 1069 recognized



**Call for your no obligation
sample today!**

CREST

HEALTHCARE[®]

 800.328.8908

 800.369.9207

 CrestHealthcare.com

LATEX-FREE

OXYGEN SAFE

2
YEAR
WARRANTY

RECOGNIZED
COMPONENT

Intertek

WHY CUSTOMERS CHOOSE CREST HEALTHCARE

CREST HEALTHCARE®



WHY CUSTOMERS CHOOSE CREST OVER CURBELL

- ✓ Lower cost
- ✓ Automatic Healthcare TV programming
- ✓ IR for Non-Healthcare Grade TVs
- ✓ Superior audio
- ✓ Crisp gentle press buttons
- ✓ Designed for infection control
- ✓ Durable nick-resistant case
- ✓ Low flat fee Crest repairs or DIY



CREST Elite Digital™
with **AutoSense™** or
Elite Infrared™

Curbell Gen4
Pillow Speakers

***AutoSense™** proprietary technology saves time by automatically detecting and connecting the pillow speaker to any healthcare grade TV and associated networks, requiring no programming. **Elite Digital™** is a registered trademark of Crest Healthcare. Crest's patented Infrared technology reduces costs through installation of less expensive consumer/commercial grade TVs through the use of infrared technology.

CREST
HEALTHCARE®

800.328.8908

800.369.9207

CrestHealthcare.com

Pillow Speaker Repairs



Crest Repairs

Save valuable time by sending in your Crest pillow speakers to our dedicated repair specialists, who will inspect, clean, repair and test them before returning them to you.

All repairs by Crest are covered by a 90 day warranty. Pillow speakers with bio-medical contamination cannot be repaired for the safety of our employees and will be disposed of properly.

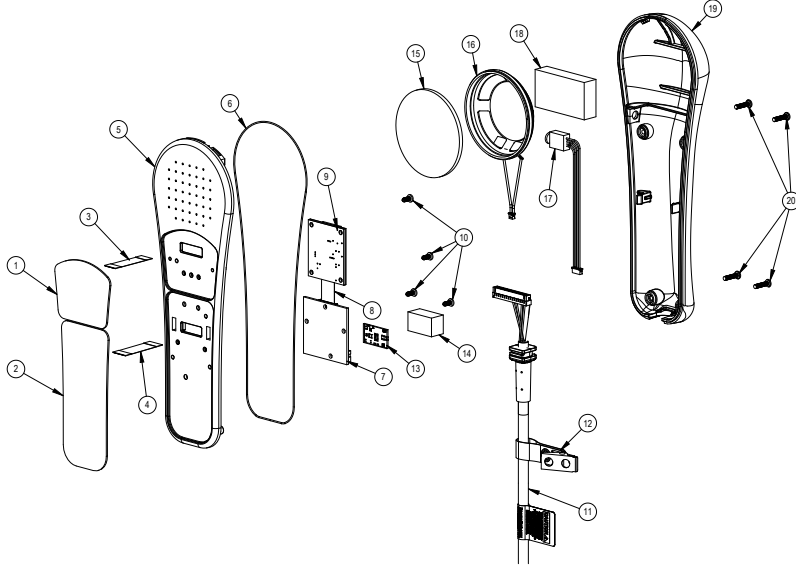

Do It Yourself Repairs

Many Crest pillow speaker users choose to repair pillow speakers on-site at their facility. Repair kits and parts are available from Crest.

Please call our Technical Support Department toll free at 833-421-0294 or use our website chat function to determine the appropriate repair kits or parts for the model of your Crest pillow speakers. Pillow speakers should be repaired in an Electrostatic Discharge (ESD) safe environment.

Other Repairs

Crest's knowledgeable repair specialists can also repair your HD2 bed controls, call cords, and most stations. An evaluation fee may be applied on products not under warranty which need to be sent elsewhere for repair.

Contact Crest Customer Service for a flat rate quote on these repairs. All repairs by Crest are covered by a 90 day warranty. Products with biomedical contamination cannot be repaired for the safety of our employees and will be disposed of properly.



It's Easy to Use the Crest Repair Service:



1) Contact Crest Customer Service at **1-800-328-8908** to request a Sales Return (SR) number.



2) Gather the following information and include it with the product sent in for repair.

- **Contact name & phone number**
- **Return address (street address, not PO box)**
- **SR number received from Crest**
- **Explanation of issue needing repair**
- **Special instructions, if any**



3) Select method of return shipping. Ground averages 4-5 days in each direction, or choose 1, 2 or 3 day shipping.



4) Write your assigned SR number on outside of shipping box.



5) Ship to:
Crest Healthcare
195 Third Street South
Dassel, MN 55325

Send products by your choice of carrier. Crest does not issue call tags for repairs.



Do you have any additional questions?
Call **1-800-328-8908** to speak with one of our Customer Service Representatives.

Note: Please call to request a Sales Return (SR) number prior to sending in your product to ensure expedited repairs.

90

DAY WARRANTY
ON REPAIRS

100%
Satisfaction
Guaranteed!

CREST
HEALTHCARE®

800.328.8908

800.369.9207

CrestHealthcare.com

CLEANING PRODUCT GUIDELINES

We understand the critical importance of disinfecting and sanitizing in healthcare environments.



APPROVED CLEANING & DISINFECTING PRODUCTS

These products are safe for Crest Pillow Speakers, Call Cords and Bed Controls.

- Germicidal disposable wipes
- Germicidal detergent
- Disinfectant cleaner
- 10% bleach
- 70% Isopropyl alcohol
- Other mild detergents



DAMAGING CLEANING & DISINFECTING PRODUCTS

The following chemicals may damage the product. Their use will void the warranty.

- Acetone
- Ammonia
- Aromatic solvents
- Other like chemicals

Also Note

While every attempt has been made to make Crest products as moisture resistant as possible, these devices are NOT submersible.

Crest products are made with durable and rigorously tested materials, however frequent exposure to solvents does degrade casings and cables.

Hydrogen peroxide-based cleaning solutions may cause yellowing to plastics. Related cosmetic issues are not covered by the warranty.

Condition of Warranty

Incorrect cleaning of products will result in the cancellation of warranty terms.

Additional Questions?

Call our friendly Customer Service Team at 800-328-8908.

CREST
HEALTHCARE®

 800.328.8908

 800.369.9207

 CrestHealthcare.com



Crest Facility & Clinical Management Solutions

- Providing healthcare solutions for over 50 years
- More than 9,000 products, over 100 new items
- Serving over 45,000 healthcare facilities
- Technical support for facility staff
- Repair services

CREST
HEALTHCARE®

 800.328.8908

 800.369.9207

 [CrestHealthcare.com](https://www.CrestHealthcare.com)